

Re. No.	DESCRIPTION	DATE	DS.	CH.	AP.
△					
△					
△					

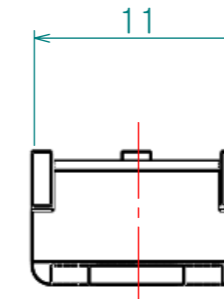
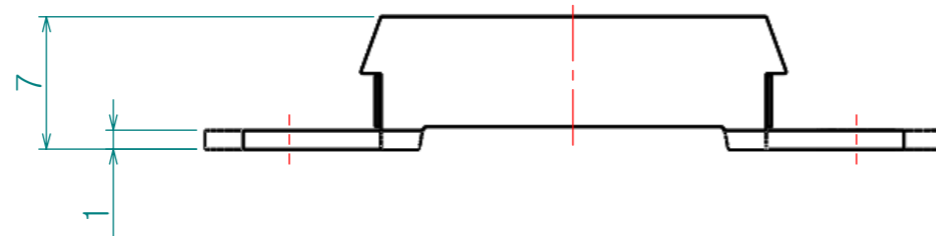
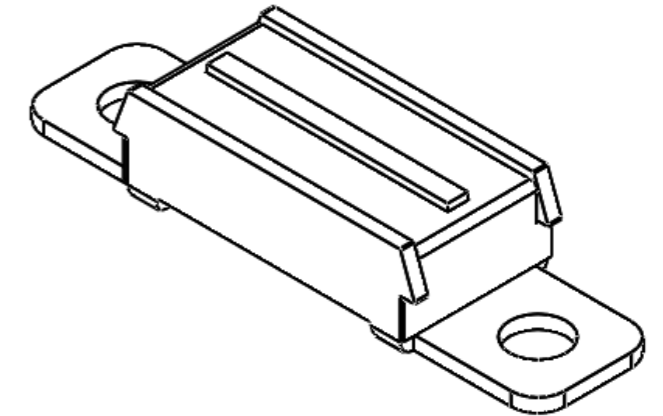
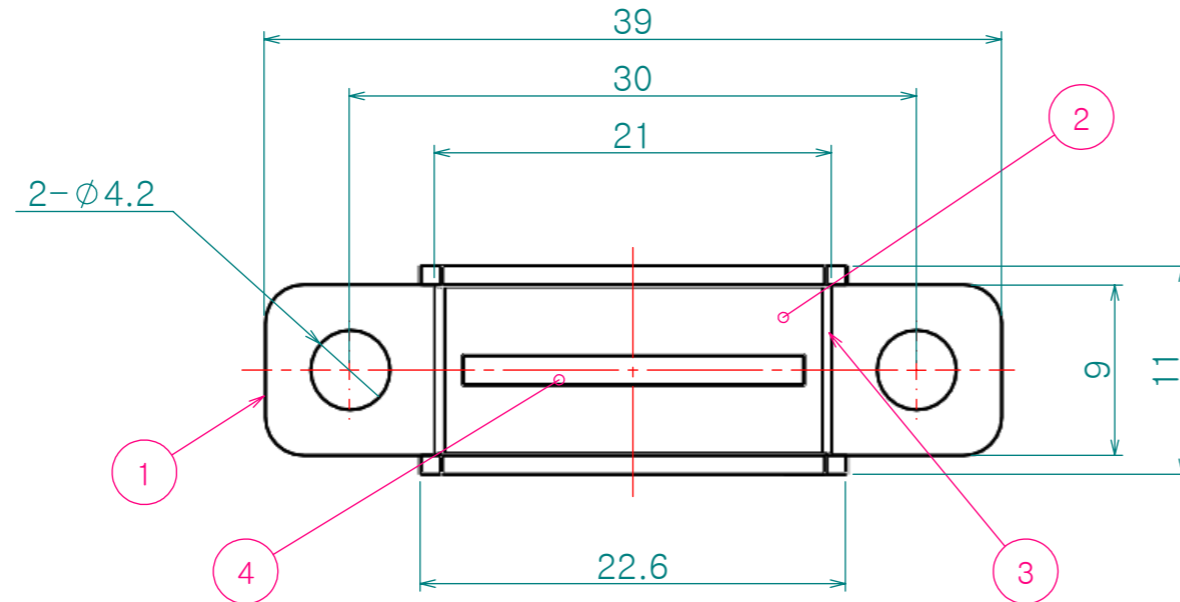

No.	부 품 명	재 질	표면처리
1	Yoke	Stainless Steel (SUS430)	광택연마
2	Magnet	Samarium Cobalt	일반
3	Cover	Stainless Steel (SUS304)	일반
4	Yock	Stainless Steel (SUS430)	광택연마

STAINLESS STEEL MAGNETIC CATCH				
제 품 명	흡착력		무게	사용온도
CC-MC-YN005HP-50	50N	5.1kg	11g	250°C

Dimension (mm)	Precision	Material **	Dwg. No.	QTY *EA	
0.5~3	±0.05	Finish **	Part Name. **	Weight -	
3~6					
6~30	±0.1	Revision -	Sheet Size A3	Ass'y Name **	
30~120	±0.15				Scale 2.5:1
120~315	±0.2				
315~1000	±0.3	Date 2013-12-14	Designed by <i>Shin S H</i>	Model No. CC-MC-YN005HP-50	
1000~2000	±0.5	Checked by	Approved by		
KS B 0412에 준함					